

# Smart Warming: Lab VIEW- Powered Patient Mattress for Ultimate Comfort

**R.Balamurugan**

PG Scholar, Dept of Medical Electronics,  
Sengunthar Engineering College (Autonomous),  
Tiruchengode, Tamil Nadu, INDIA  
[kkrbalabme@gmail.com](mailto:kkrbalabme@gmail.com)

**Dr.R.SatishKumar**

Professor, Dept of Medical Electronics,  
Sengunthar Engineering College (Autonomous),  
Tiruchengode, Tamil Nadu, INDIA  
[harsiga@gmail.com](mailto:harsiga@gmail.com)

**Prof.Muhammadu Sathik Raja**

Professor, Dept of Medical Electronics,  
Sengunthar Engineering College (Autonomous),  
Tiruchengode, Tamil Nadu, INDIA  
[scewsadik@gmail.com](mailto:scewsadik@gmail.com)



## Publication History

**Manuscript Reference No:** IJIRIS/RS/Vol.10/Issue02/FBIS10094

Research Article | Open Access | Double-Blind Peer-Reviewed | Article ID: IJIRIS/RS/Vol.10/Issue02/FBIS10094

Received: 24, January 2024 | Revised: 12, February 2024 | Accepted: 18, February 2024 | Published Online: 29, February 2024  
Volume 2024 | Article ID FBIS10094 <http://www.ijiris.com/volumes/Vol10/iss-02/15.FBIS10094.pdf>

**Article Citation:** Balamurugan, Sathish, Muhammadu (2024). Smart Warming: Lab View – Powered Patient Mattress for Ultimate Comfort. International Journal of Innovative Research in Information Security (IJIRIS), Volume 10, Issue 02, Pages 107-114 <https://doi.org/10.26562/ijiris.2024.v1002.15> **BibTex key:** Balamurugan@2024Smart



Copyright: ©2024 This is an open access article distributed under the terms of the Creative Commons Attribution License; which Permits unrestricted use, distribution, and reproduction in any medium, provided the original author and source are credited.

**Abstract:** Exposure to cold temperatures is, often, a neglected problem in ICUs, CT, AND MRI scans it may cause several discomforts such as shivering, lung diseases, and artifacts in scan reports, etc., one of the leading influences of the overall sensation of cold discomfort is the cooling of the back. This study aimed to evaluate the effect of a heated ambulance mattress- prototype on body temperatures and thermal comfort in an experimental study. The endotherm patient warming mattress and ambulatory patient mattress are the preexisting projects. The Inditherm mattress is designed for use by all patients undergoing anesthesia who may be at risk of inadvertent pre-operative hypothermia, and for any patients who require warming in pre-operative, intra-operative, and postoperative settings the ambulatory mattress is generally a warming mattress. The main disadvantage is that these two technologies are not automated the operator has to set all parameters. In this project, we are designing a mattress that liberates heat depending on room temperature. The Lab VIEW controls on and off of the system it compares the room temperature with the present value and produces a suitable result. The main advantage is the project is fully automated and warms the patient only at the required time.

**Keywords:** Heat, Inditherm mattress, Patient Warming Mattress, Room Temperature

## I. INTRODUCTION

Prehospital care is vital for managing patients during emergencies, with cold exposure often underestimated but potentially life-threatening, particularly in situations of grave danger such as serious injuries or severe illnesses. Inadequate protection from cold can have adverse effects on the human body, exacerbating existing conditions and compromising patient well-being. Recognizing this vulnerability is essential for enhancing the quality of prehospital care. Interventions, including insulation, warming techniques, and vigilant monitoring, are crucial to prevent and mitigate the adverse effects of cold exposure. Hypothermia serves as an independent predictor of increased morbidity and mortality regardless of injury severity. Various studies outline the physiological effects of hypothermia, identifying factors that impair the body's natural thermoregulatory mechanisms, such as fatigue, nervous system injuries, medications, and the influence of substances like alcohol or drugs. Additionally, aggravating circumstances include age, female gender, chronic illness, trauma, starvation, and endocrine diseases. Hypothermia has traditionally been defined by body core temperature. The effects of low temperature, as described in a review, involve cold exposure triggering peripheral vasoconstriction, directing peripheral blood to central body regions to support vital organs and retain heat. The initial cold is experienced and observed in the hands and feet, with the back cooling quickly. Despite injury, patients outdoors in cold environments express anxiety about freezing to death. Maintaining a constant body temperature between 36–38°C, optimal for physiological functions, is challenging. Patients may have a negative experience before reaching hypothermia, emphasizing the importance of active heat supply and warmth for their well-being.

Concerning temperature ranges in ICU and CT scanning rooms, the operating temperature should ideally be around 72°F, with the average temperature typically ranging between 17-22 degrees Celsius. Comparatively, our normal body temperature is 36 degrees Celsius. Warming interventions, such as wrapping patients with warm blankets, significantly reduce anxiety and improve overall patient experience. Similar positive outcomes are observed in elderly patients receiving external heat supply. Thermal comfort is essential for psychological and physiological well-being, emphasizing the importance of warmth in prehospital care. In prehospital settings, studies focus on heat sources like chemical heating pads, hot water bottles, charcoal heaters, hot air blankets, and reflective blankets. However, limitations exist in equipment for reducing risks that may decrease thermal comfort for patients, such as the SMART WARM PATIENT MATTRESS. Despite the availability of warm intravenous fluids in prehospital care, ambient temperatures lower than 37°C may lead to the fluids adapting to the ambient temperature, contributing to a decrease in body temperature.

## 2. LITERATURE REVIEW

In the study by Lintu et al. (2006) [3], cold exposure emerges as a significant yet often overlooked concern in prehospital care. The authors note its subjective discomfort and potential for disrupting vital functions, gradually leading to hypothermia. They observed a decrease in pulse wave amplitude and skin temperatures, especially in extremities, during cold exposure. Despite the absence of significant tympanic membrane temperature decrease, the subjective feeling of cold persisted even after skin temperatures failed to return to normal levels within 30 minutes post-exposure. Aitken et al. (2009) [1] aimed to identify factors associated with hypothermia (<35 degrees C) in trauma patients in Queensland. Their retrospective analysis of Queensland Trauma Registry data from 2003-2004 explored hypothermia's correlation with mortality, ICU admission, and hospital length of stay among patients with an injury severity score (ISS) >15. Hultzer et al. (2005) [2] conducted a comparative study of five active torso-warming modalities in severe hypothermia cases with shivering inhibited by intravenous meperidine. Their human model trials evaluated methods like forced-air warming, rigid covers, charcoal heaters, and body-to-body contact with non-thermic partners, assessing their efficacy in rewarming subjects cooled in 8 degrees C water. Watts et al. (1999) [5] investigated the impact of hypothermia on metabolic and hemostatic functions in trauma patients and evaluated various prehospital rewarming measures' effectiveness. Their prospective study randomized ALS units to provide routine care alone or in conjunction with active warming methods like reflective blankets, hot pack rewarming, or warmed IV fluids. Sessler (2001) [4] highlighted the challenges of defining and managing mild hypothermia in surgical patients, noting its prevalence due to anesthetic-induced thermoregulatory impairment and cool operating room environments. The review underscores the need for consistent terminology and vigilance in addressing mild hypothermia's complications.

## 3. PROPOSED METHODOLOGY

### 3.1. INTRODUCTION

The objective of this project is to design a smart mattress that leverages LabVIEW's real-time sensor measurements to control heat adjustments based on ambient temperature. The mattress's inbuilt sensors provide data to the central control system, LabVIEW. A responsive mattress that adjusts to changes in the surrounding environment to provide users with the best possible comfort is the aim. The flexibility of LabVIEW allows for quick changes in heat release, which encourages energy conservation. Users can program the system to a temperature of their choice, and safety features guard against overheating. By utilizing LabVIEW for intelligent control and establishing a new benchmark for responsive and customized sleep technology, this ground-breaking method seeks to revolutionize the design of mattresses.

### 3.2. PRINCIPLE

The peltier effect generates temperature differences by transferring heat between two electrical connections. A voltage is supplied across linked conductors to generate an electric current. When current travels between the junctions of two conductors, heat is eliminated at one junction, resulting in cooling. Heat is deposited at the other end.

### 3.3. BLOCK DIAGRAM

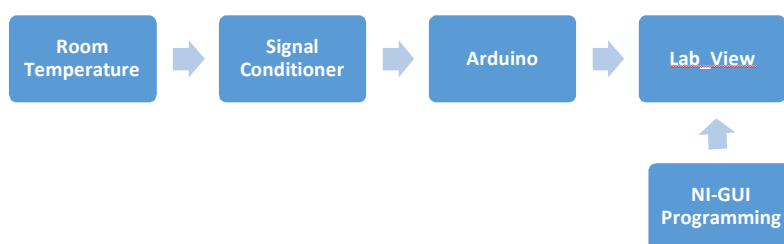

Fig. 1. Block Diagram

### 3.4. CIRCUIT DIAGRAM

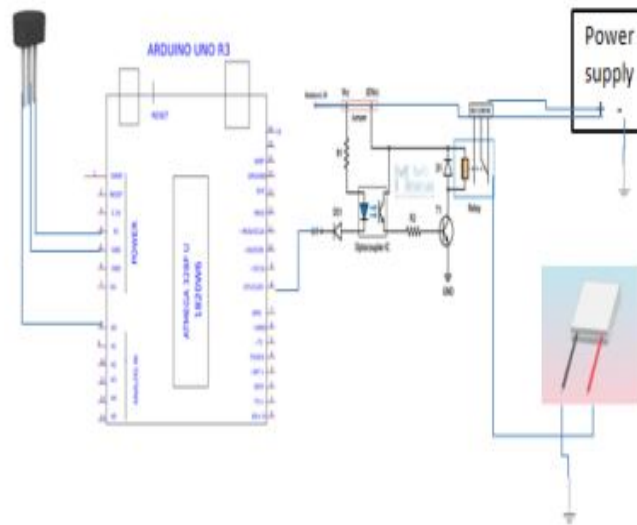

Fig. 2. Circuit diagram

## 4. COMPONENTS REQUIRED

### 4.1. ARDUINO

Arduino was developed at the Ivrea Interaction Design Institute as a simple tool for quick prototyping, with a focus on students who had no prior experience with electronics or programming. Initially developed for ease of use, the Arduino board evolved to suit a variety of challenges and needs as its popularity grew. It evolved from simple 8-bit boards to solutions suitable for IOT applications, wearables, 3D printing, and embedded systems. Notably, all Arduino boards and software are completely open source, encouraging users to build and customize them according to their specific needs. The collaborative contributions of people around the world fuel the growth and development of Arduino's open-source software.



Fig. 3. Arduino

### 4.2. LM35 SENSOR

The LM35 is a precision integrated circuit temperature sensor whose output voltage fluctuates according to the temperature surrounding it. It is a compact and inexpensive IC that can monitor temperatures ranging from  $-55^{\circ}\text{C}$  to  $150^{\circ}\text{C}$ . It is easily interfaced with any microcontroller with an ADC function or any development platform, such as Arduino. Power the IC by supplying a controlled voltage, such as +5V (VS), to the input pin and connecting the ground pin to the circuit ground.

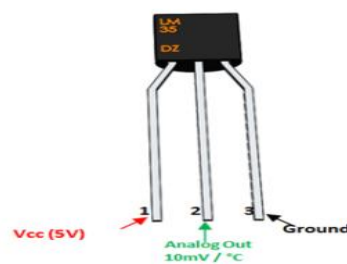

Fig. 4. LM35 sensor

### 4.3. PELTIER MODULE

Peltier modules are electronic devices used to cool objects below ambient temperature or to keep objects at a specified temperature through controlled heating or cooling. This technology is far less commonly used in refrigeration than vapor-compression refrigeration. The primary advantages of a Peltier cooler over a vapor-compression refrigerator include the absence of moving parts or circulating liquid, a very long life, leak resistance, small size, and flexible shape. Its main drawbacks are expensive cost per cooling capacity and low power efficiency. Many researchers and firms are working to build low-cost, high-efficiency Peltier coolers. A Peltier cooler can also operate as a thermoelectric generator. When operating as a cooler, a voltage is delivered across the device, causing a temperature difference to develop between the two sides. When used as a generator, one side of the device heats to a higher temperature than the other, resulting in a voltage differential between the two sides (the Seebeck effect). However, a well-designed Peltier cooler will be a mediocre thermoelectric generator, and vice versa, because of dissimilar design



Fig. 5. Peltier module

### 4.4. RELAY

A relay is a type of electrical switch that has both control signal input terminals and functioning contact terminals. They originated in long-distance telegraph networks, telephone exchanges, and early computers, and control circuits with low-power signals or numerous circuits. Traditional relays use an electromagnet, but solid-state relays rely on semiconductor characteristics. Relays with calibrated characteristics and several coils protect circuits against overloads and failures. Latching relays require only one pulse of control power.



Fig. 6. Relay

### 4.5. LabVIEW

LabVIEW is a system design platform and development environment for National Instruments' Visual Programming Language "G". It can be used for data collecting, instrument control, and industrial automation on a variety of operating systems, including Microsoft Windows, UNIX, Linux, and Mac OS. The most recent versions of LabVIEW are LabVIEW 2019 SPI and LabVIEW NXG 4.0, both published in November 2019. LabVIEW enables users to create a user interface with controls and indicators such as knobs, push buttons, dials, and graphs, as well as add code to operate front panel objects via VIs and structures. It is compatible with hardware like as data acquisition, vision, and motion control devices, as well as GPIB, PXI, VXI, and RS232. LabVIEW includes built-in template VIs for developing common measuring applications.

#### 4.5.1. Front Panel

The Front Panel is used to engage with the user while the program is running.

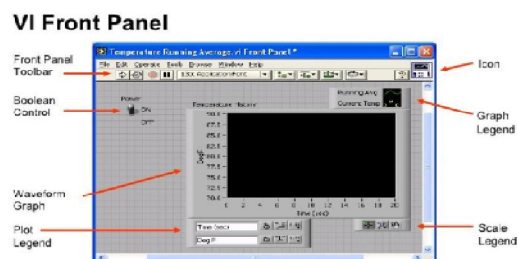

Fig. 7. VI front panel

Users can control the program, adjust the inputs, and view real-time data updates. Stress that controls are used for inputs, such as changing a slide control to set an alert value, turning a switch on or off, or terminating a program. Indicators serve as outputs. Thermometers, lights, and other indicators show the program's values. These could comprise statistics, program statuses, or other information. On the block diagram, each front-panel control or indicator corresponds to a terminal. When a VI is run, values from controls travel through the block diagram, where they are employed in the functions on the diagram, and the results are given to other functions.

#### 4.5.2. NI LAB VIEW BLOCK DIAGRAM

This graphical source code is contained within the block diagram. The block diagram shows front panel objects as terminals. Furthermore, the block diagram includes functions and structures from the built-in LabVIEW VI libraries. Wires connect all of the nodes in the block diagram, including control and indicator terminals, functions, and structures.

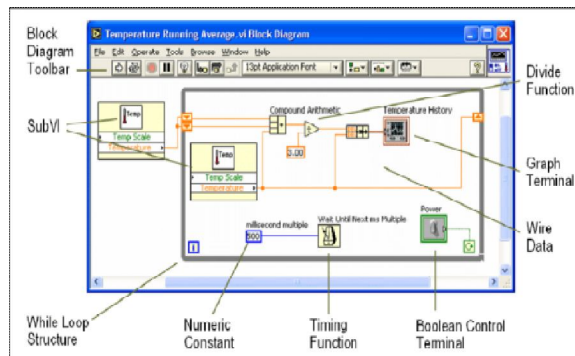

Fig. 8. NI Lab View block diagram

#### 4.5.3. CONTROL PALETTE

To add controls and indicators to the front panel, use the Controls palette. Only the front panel has access to the Controls palette. Either right-click on the front panel workspace or select Window>>Show Controls Palette to open the Controls palette. Alternatively, you can right-click on any empty space on the front panel to activate the Controls palette. Click the pushpin in upper left corner to tack down the Controls palette.



Fig. 9. Control Palette

#### 4.5.4. FUNCTION PALETTE

To create the block diagram, use the Functions palette. The Functions palette is only visible in the block diagram. To access the Functions palette, go to Window>>Show Functions Palette or right-click on the block diagram workspace. You may also access the Functions palette by right-clicking an open spot on the block diagram. Tack down the Functions palette by clicking the pushpin in the top left corner.

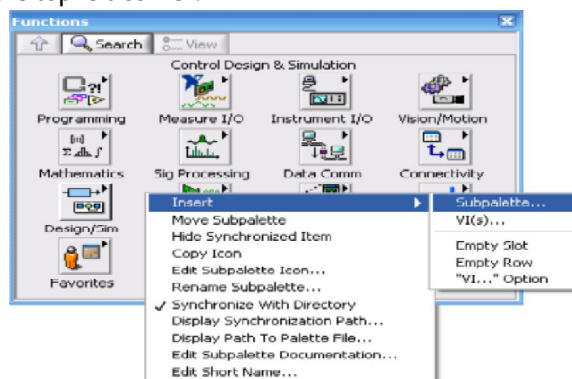

Fig. 10. Function Palette

#### 4.5.5. WHILE LOOP

A While Loop is a structure that executes a block of code repeatedly until a specific condition is met. When the VI runs, the code inside the While Loop is executed, followed by the evaluation of the terminal condition. Unlike a For Loop, the execution of a While Loop is not limited by the number of iterations; consequently, if the condition never occurs, the loop will continue indefinitely.

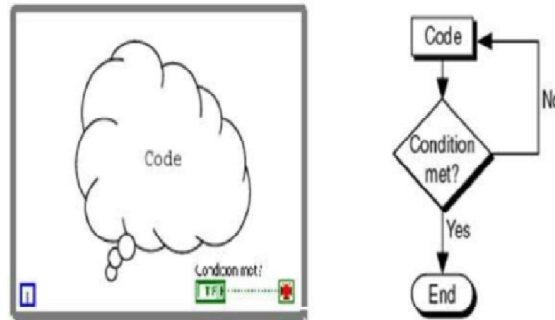

Fig. 11. While Loop

#### 4.5.6. FOR LOOP

A While Loop is a structure that allows you to execute a block of code continuously until a specific condition is met. When the VI runs, the code inside the While Loop is executed, and the terminal condition is evaluated. Unlike a For Loop, the execution of a While Loop is not limited by the number of iterations; consequently, if the condition never occurs, the loop will run indefinitely.

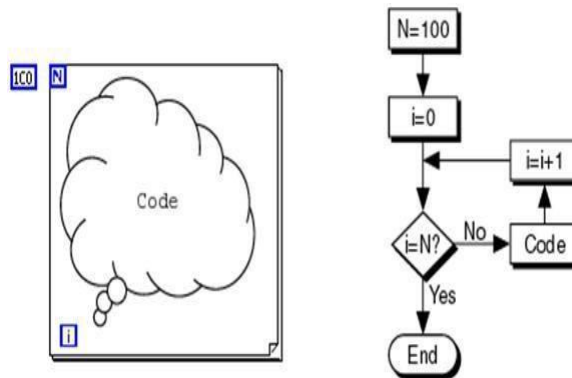

Fig. 12. For Loop

### 5. WORKING

- The LM35 sensor accurately measures ambient room temperature.
- The LM35 sensor sends temperature data to LabVIEW via an Arduino board, which acts as a data acquisition device.
- LabVIEW acts as a central control system, analyzing temperature data in real time.
- LabVIEW compares measured room temperature to specified values to make intelligent decisions.
- If the room temperature falls below the predetermined value, LabVIEW activates a relay.
- When the relay is triggered, the Peltier module begins to generate heat.



Fig. 13. Software & Hardware Set up

- The Peltier module allows the mattress to release heat, providing a warm and comfortable resting surface.

- LabVIEW deactivates the relay when the room temperature reaches or surpasses the predefined threshold.
- The disabled relay prevents the Peltier module from generating superfluous heat.
- This dynamic control system promotes user comfort while increasing energy conservation by preventing continuous operation of the heating element when not required.

## 6. RESULT

Once the Warm Patient Mattress using LabVIEW has been made according to the instructions, the project is ready for testing with the LabVIEW software. The following findings were obtained.

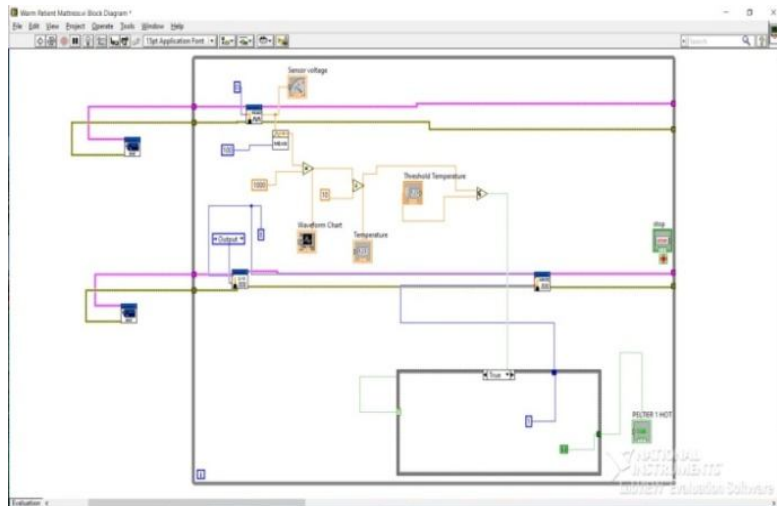

Fig. 14. Block Diagram

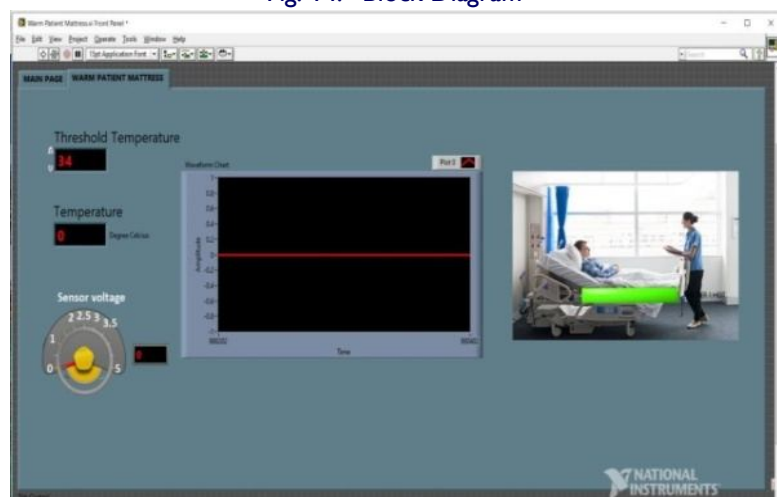

Fig. 15. Front Panel

### 6.1 RESULTS OF PELTIER MODULE DURING ON/OFF CONDITION

#### 6.1.1 CASE I

By using these procedures in the LabVIEW tool, if the room temperature is less than the present value, the result will be as shown in the Figure 15.

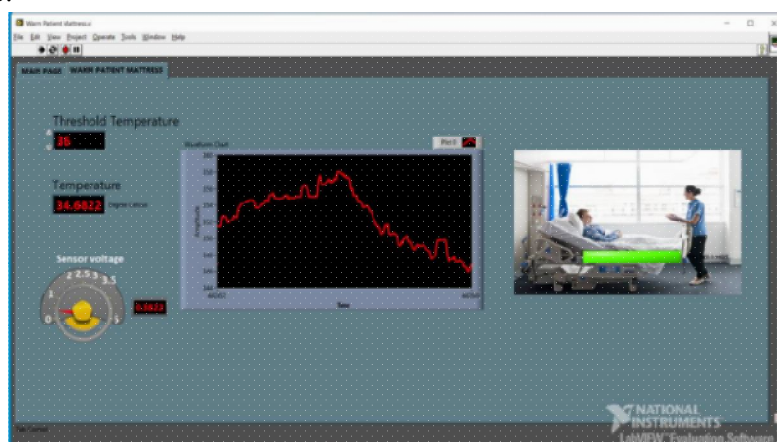

Fig. 16. Peltier Module at ON Condition

### 6.1.2 CASE 2

If the room temperature is greater than or equal to present value, the result will be as shown in the Figure 16.

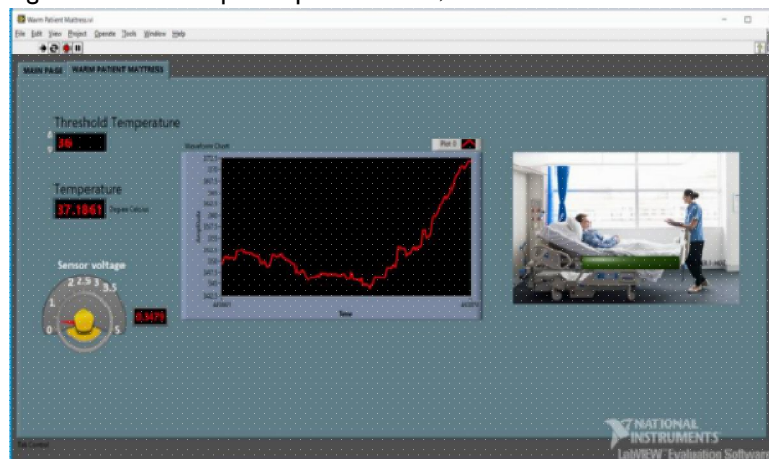

Fig. 17. Peltier Module at OFF Condition

## 7. CONCLUSION

The temperature in ICUs, CT, MRI scanning rooms, and operating rooms is kept extremely low, which can cause patients to shiver, experience vasoconstriction, develop lung ailments, and other issues. It is vital to keep the patient warm in these severely cold environments. In this project, we built a patient mattress that would release a set amount of heat based on the room temperature. The system is totally controlled via LabVIEW. This mattress is also suitable for people recovering from surgery following general anaesthesia. This heated patient mattress is totally automated and does not require any operators to activate. Lack of sleep is also a key cause of many ailments, thus it can be used in conjunction with smart beds. This system is completely accurate.

## REFERENCES

- [1]. Aitken LM, Hendrikz J, Dulhunty J and Rudd M (2009) 'Hypothermia and associated outcomes in seriously injured trauma patients in a predominantly sub-tropical climate', *Resuscitation* 2009, Volume 80(2), PP 217–223.
- [2]. Hultzer MV, Xu X, Marrao C, Bristow G, Chochinov A and Giesbrecht GG (2005) 'Prehospital torso-warming modalities for severe hypothermia: a comparative study using a human model', *Can J Emerg Med* 2005, Volume 7(6), PP 378–386.
- [3]. Lintu NS, Mattila MAK, Holopainen JA, Koivunen M and Hänenen OOP (2006) 'Reactions to cold exposure emphasize the need for weather protection in prehospital care: an experimental study', *Prehospital Disaster Med* (September – October) 2006, Volume 21(05), PP 316–321.
- [4]. SesslerDI (2001) 'Complications and treatment of mild hypothermia', *Anesthesiology* 2001, Volume 95(2), PP 531–543.
- [5]. Watts DD, Roche M, Tricarico R, Poole F, Brown JJ, Colson GB, Trask AL and Fakhry SM (1999) 'The utility of traditional prehospital interventions in maintaining thermo stasis', *Prehospital Emergency Care* 1999, Volume 3(2), PP 115–122.